

 newbits

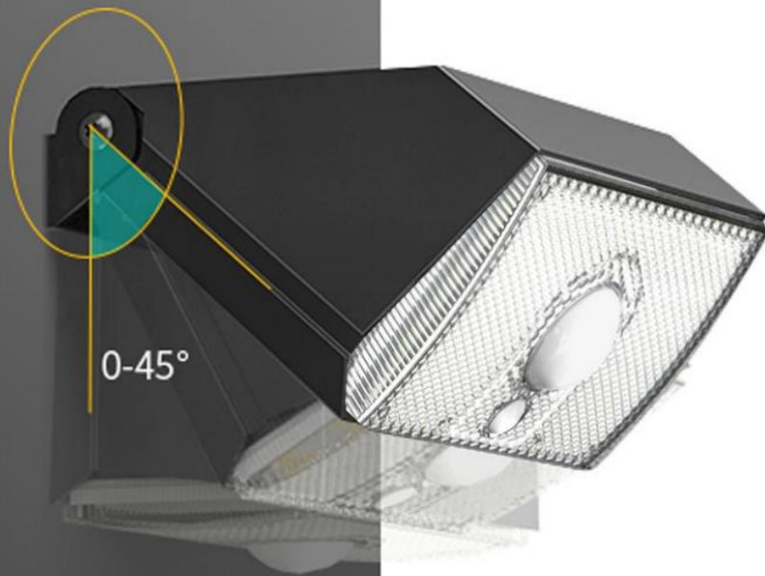

MARS 1

LAMPĂ SOLARĂ DE PERETE



# INTRODUCERE

Specificațiile produsului

01 INTRODUCERE

02 CATALOG

03 AVANTAJE PRINCIPALE

04 ALTE AVANTAJE

05 SPECIFICAȚII

06 REPREZENTARE OPTICA

07 DIMENSIUNI

08 MAI MULTE DETALII

09 TEHNOLOGIE NUCLEU

10 DETALII PACHET

11 UTILIZARE

LAMPĂ SOLARĂ DE PERETE DE URGENȚĂ, 1000LUMENI, SUPER LUMINOASA



Dimensiune VS iPhone X

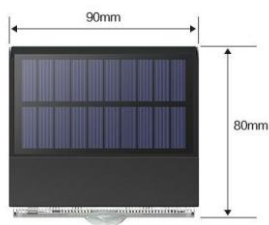

TEHNOLOGIE DE DISIPARE A CALDURII CARCASEI

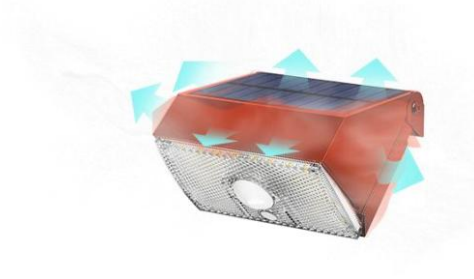

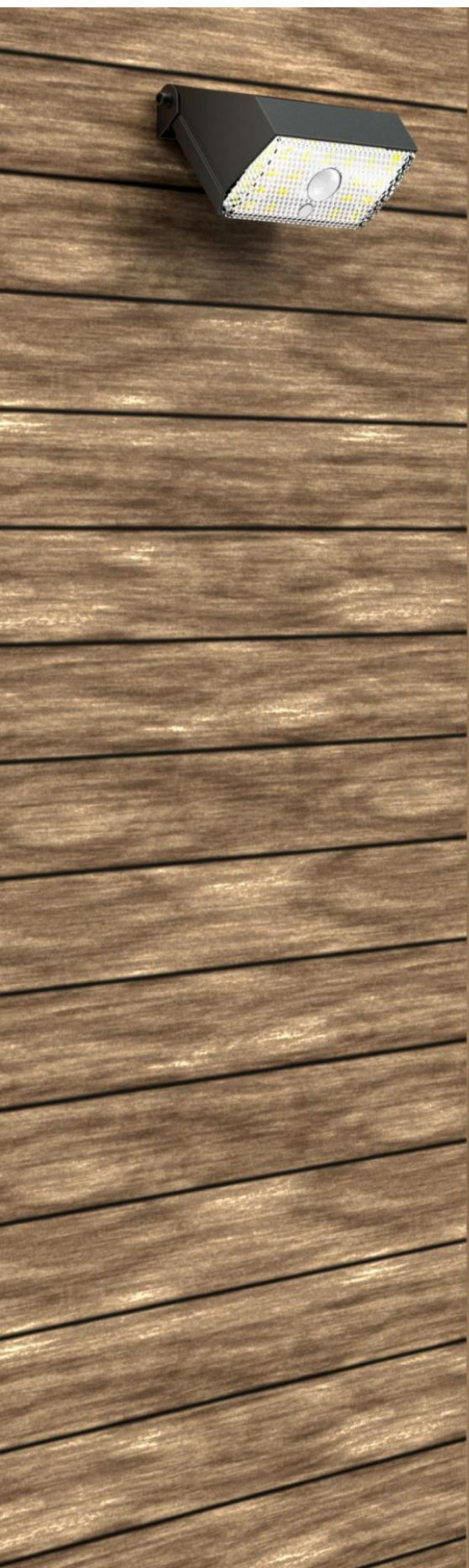

## MODURI DE INSTALARE MULTIPLE



CABLU DE PRINDERE

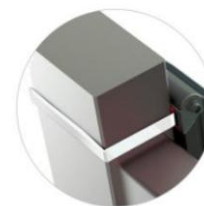

CABLU DE PRINDERE



SURUB



AVANTAJE:  
MODALITATI MULTIPLE DE INSTALARE  
MULTI UNGHI  
AJUSTABILA  
TEHNOLOGIE PATENTATA ALS 2.1  
UTILIZARE DURABILA PRIN TEHNOLOGIA TCS

Articol: SWL-11

Putere 10 W

## Panou solar

Putere

Policristalin, 0,5 W

## Baterie Li-ion

Capacitate

3.7V7.4WH 2.0AH/PC

Temp. de încărcare/descărcare

0~45°C/-20~60°C

Timp de incarcare

20H

LED (OSRAM)

2835 20 buc

Temp. culoare

4000K Ra 80+

Eficienta

190lm/W

LED UV

-

## Performanta

Timp de iluminare în zilele ploioase

&gt;10 zile

Modul de control

Buton comutator, ON/OFF Apăsare lungă 1,5 secunde

Modul de iluminare

M1: 0LM+PIR 1000LM(10S)

M2: 20LM+PIR 1000LM(10S)

M3: 20LM

Indicarea modului

-

Indicație de capacitate

-

PIR

120 ° , &gt;5m

Tehnologia de bază

ALS 2.1 / TCS 1.0

Autocurățare panouri solare

-

Clasa IP/IK

IP65 / IK10

Înălțime de instalare

2,0 M-3,0 M

Diagrama simulată a drumului

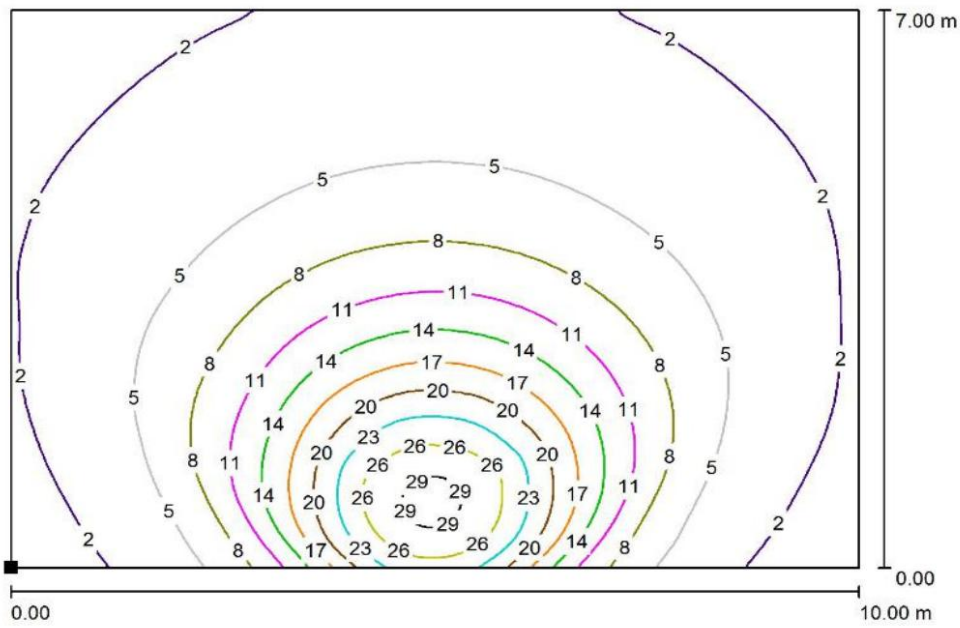

Curba de iluminare

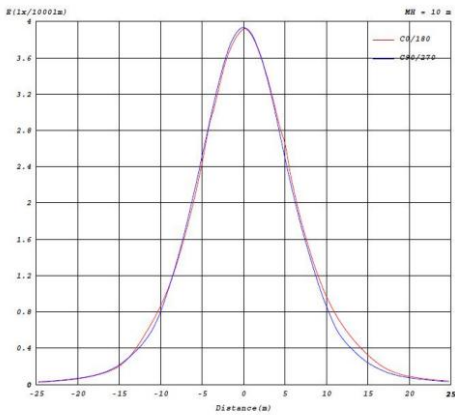

Distribuția Luminanței

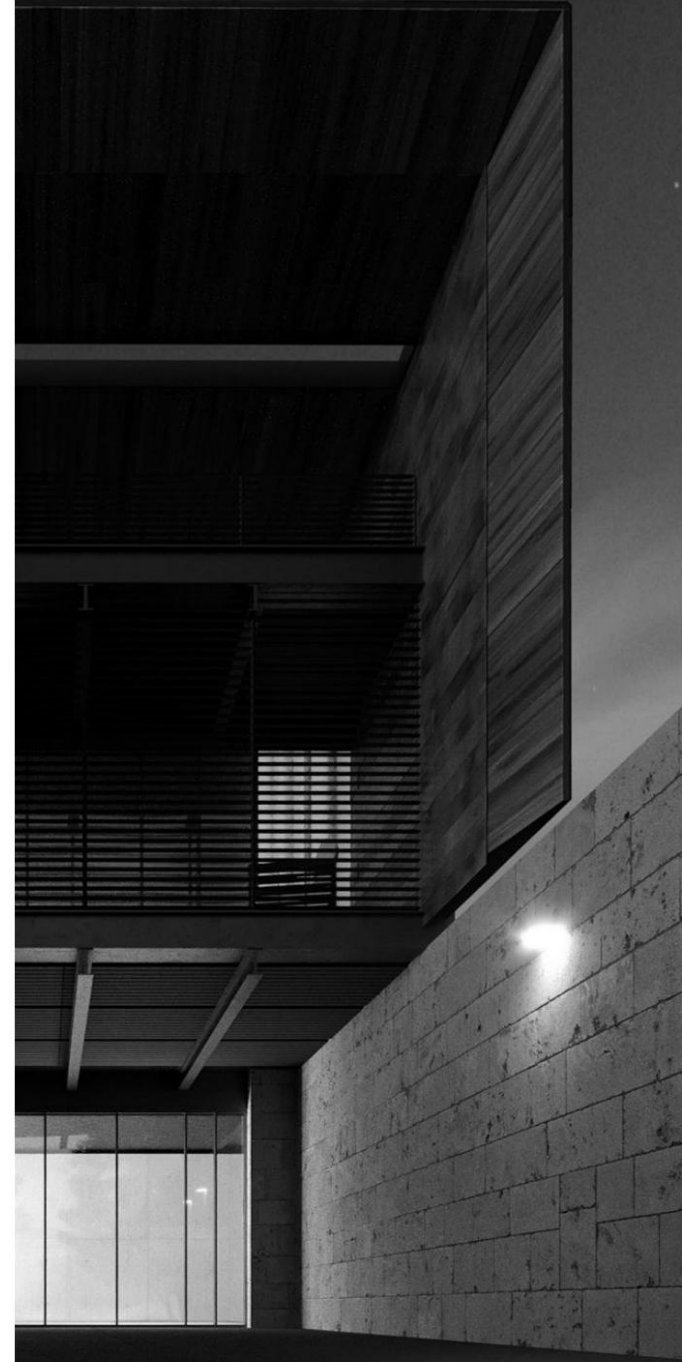
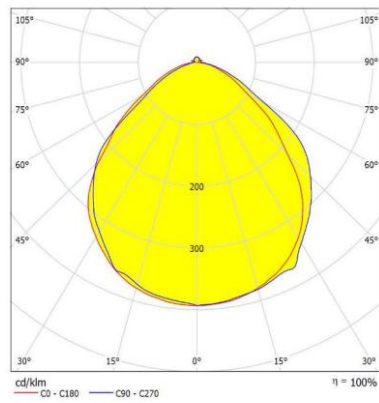

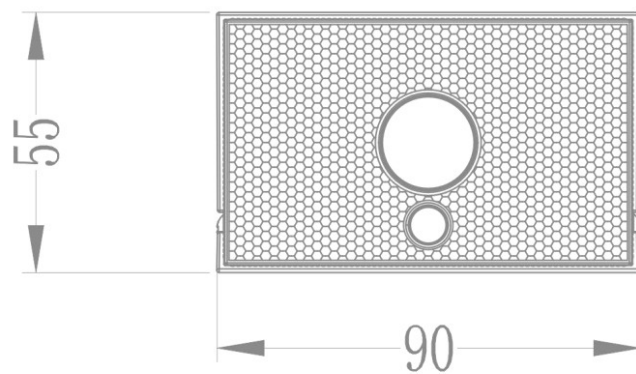
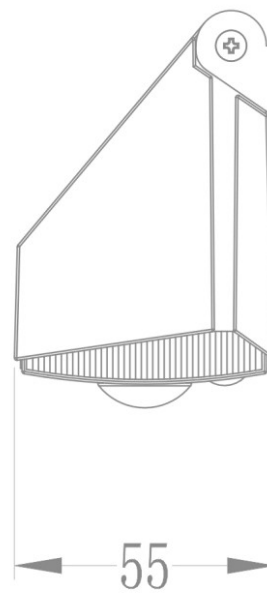
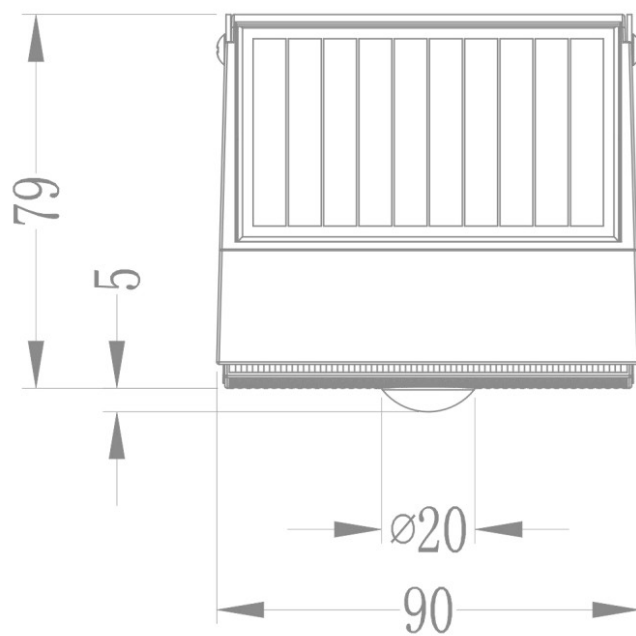

## BENEFICII

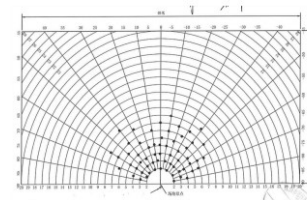

Eficiența de încărcare solară policristalină: >19%

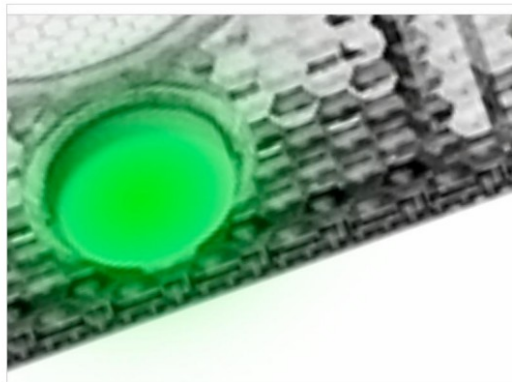

Comutator de alimentare cu indicator de stare cu led



Reglabilă multi-unghi



LED-uri cu lumen ridicat: 190lm/W

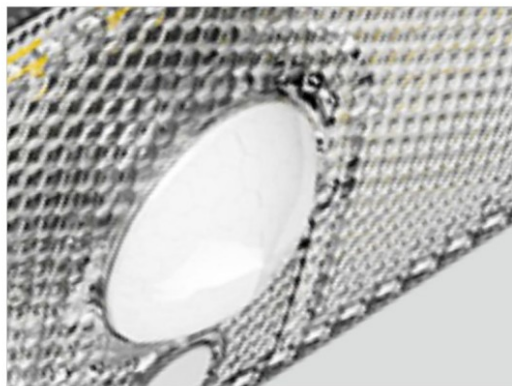

PIR : > 3m , 120°



Detalii spate



O companie mare ar trebui să acorde întotdeauna o atenție ridicată la designul fiecărui detaliu, iar spiritul de măiestrie, ar trebui completat în procesul de proiectare și producție în masă.



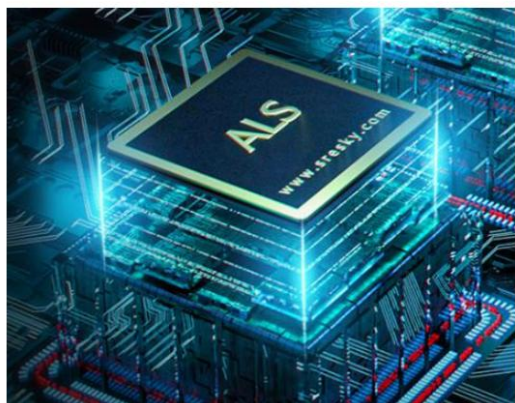

AVANTAJUL ALS

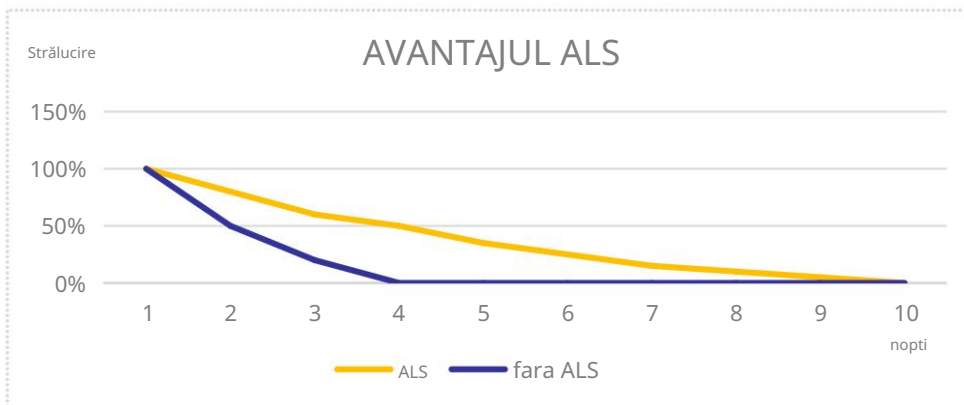

AVANTAJUL TCS

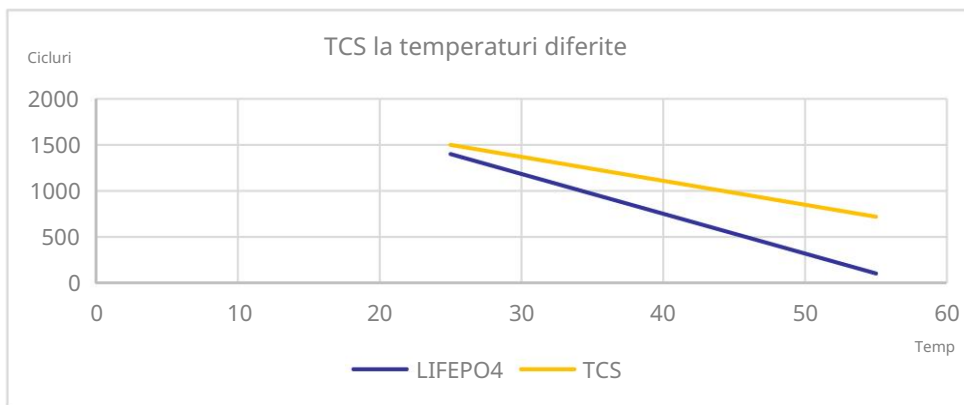

## LISTA DE PRODUSE

Șurub: 2 buc  
 Șuruburi cu expansiune: 2 buc  
 FASETE: 2 buc

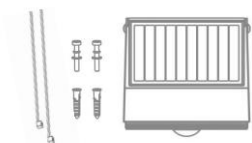

## CUTIE INTERIOARĂ

DIMENSIUNE: 9,5\*6,0\*8,7 cm  
 1BUC/1 CUTIE



3 STRATURI  
 1 STRAT = 20 CUTII

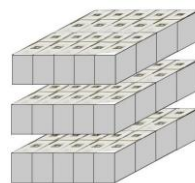

## MASTER CARTON

DIMENSIUNE: 37,2\*32,5\*30,5 cm  
 60BUC/CTN

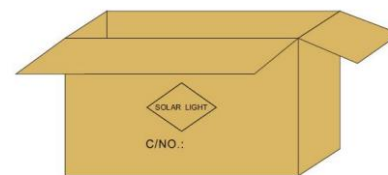

CUTIE DE CARTON

NUMĂRUL STRATULUI

CUTIE COLOR

LISTA DE PRODUSE

PASUL 1

PASUL 2

PASUL 3

PASUL 4

NUMARUL MODELULUI	METODĂ AMBALARE	PCS/CTN	CANTITATE (BUC)	CTN CANTITATE	DIMENSIUNE CUTIE (CM)	NW (KG)	GW (KG)
SWL-12	CUTIE DE CULORI	1	1	1	9,5*6,0*8,7	0,19	0,2
	CUTIE DE CARTON	60	60	1	37,2*32,5*30,5	12	12.5

Greutatea netă și greutatea brută sunt doar pentru referință

S / O / L / A / R / L / I / G / H / T

**VA MULTUMIM!**

**CONTACT:** Email: [info@newbits.ro](mailto:info@newbits.ro)